



Vehicle Microsleep Detection System Using Heart Rate Monitoring System

Noraishikin Zulkarnain¹, Muhammad Hazman Muhammad Fikri Moh^{1,*}, Nor Aziyatul Izni², Syahirah Abd Halim¹, Siti Salasiah Mokri¹, Seri Mastura Mustaza¹

¹ Department of Electrical, Electronic and Systems Engineering, Faculty of Engineering & Built Environment, Universiti Kebangsaan Malaysia, Malaysia

² Centre of Foundation Studies, Universiti Teknologi MARA, Cawangan Selangor, Kampus Dengkil Dengkil, Selangor, Malaysia

ARTICLE INFO

Article history:

Received 27 November 2026

Received in revised form 20 February 2026

Accepted 15 April 2026

Available online 4 May 2026

Keywords:

Driver; microsleep;
photoplethysmography; alarm system;
internet of things

ABSTRACT

The occurrence of sleep in a few seconds called microsleep while driving is very likely to cause traffic accidents. Currently, the microsleep monitoring system on vehicles is taken lightly. The absence of an alarm system causes the driver to be unaware of microsleep detection. In addition, existing monitoring systems have low accuracy for determining microsleep conditions. Therefore, a microsleep detection system with a heart rate input based on a photoplethysmography (PPG) sensor was designed, an alarm system on Android smartphone was used and a PPG system capable of determining the state of the driver was designed. This study uses Arduino software to process heart rate data with a peak detection algorithm method, Internet of Things (IoT) is used to trigger alarm system on a smartphone. Study results show that the PPG system can detect and act according to the state of the driver and trigger an alarm system on the smartphone when microsleep is detected. A comparison of heart rate readings on PPG system sensors with commercial sensors is taken by calculating the Pearson's correlation coefficient using 25 samples which shows $r = 0.93709$ and $r = 0.98734$ for smartwatch and pulse oximeter sensor respectively which is close to the linear correlation coefficient, $r = 1$. 25 samples were taken to determine the range of normal (79 - 63 BPM), drowsy (62 - 50 BPM) and microsleep (49 BPM and below). In conclusion, the use of the PPG system should be combined with existing sensors such as facial image sensors to determine the state of microsleep for higher accuracy.

1. Introduction

The physical condition of the driver is an important factor because it determines the driver's level of safety in driving a vehicle. A person's fatigue can cause drowsiness. This sleepy state can cause a person to microsleep [1]. driving position with regards to the driving task, should be given the utmost consideration in improving the car design and driver's condition. According to statistics, about 20% of road accidents involve drowsy drivers. Survey research shows that more than half of drivers experience drowsiness while driving at least once each year [2]. Driving efficiency and safety is not only affected by physical abilities and driving experience, but also by psychological conditions such as stress and fatigue [3].

Many studies in the past literature focused on areas associated with assessment on driving drowsiness. Table 1 shows 11 studies with different uses of main sensor conducted in the past ten years from 2013 to 2023 on the interaction between the driver and the car. Based on Table 1, the use of video processing sensor is the popular sensor that frequently used as a main sensor by the researcher. Only one study was carried out on photoplethysmography (PPG) sensor. According to Table 1, these four study types related to the driver drowsiness while driving the car but not focus on the microsleeep detection.

Table 1
 Investigation on microsleeep detection sensor

No	Reference	Main sensor			
		EEG	ECG	Video processing	PPG
1	Subha et al. [4]	x			
2	Rohit et al. [5]	x			
3	Vadlamudi & Ahmadinia [6]				
4	Gupta et al. [7]				
5	IEEE Staff [8]			x	
6	Faidhi Daud et al. [9]			x	
7	Pham et al. [10]	x	x		
8	Gromer et al. [11]		x		
9	Anilkumar et al. [12]		x		
10	Arunasalam et al. [13]	x		x	
11	Kurian et al. [14]				x

The invented system Subha et al. [4] uses an Electroencephalograph (EEG) to determine whether the driver is sleepy or normal via brain activity. In this system the PyEEG module is used to separate the wave into its constituent Alpha, Beta, Delta and Theta components and the time series is used to fit the model to the input data.

The PPG sensor system is proposed from [7] that determines the state of the driver with an inaccurate image due to the sensor camera needing bright light to work to record the image of the driver's face. A detector from the OpenCV Library is used to recognize a person's face, while a predictor from the dlib Library is used to accurately determine the location of the eyes and mouth. The aspect ratio of the eyes and the aspect ratio of the mouth are considered to determine the face that experiences microsleeep [9].

For ECG sensor the complete design consists of an amplifier and filter board for the electrocardiogram (ECG) signal, analog-to-digital conversion (ADC) and further software to process the resulting signal in a PC integrated in the car or a driving simulation. Arduino Uno is used as ADC. Analog signals are read with an Arduino, pre-processed, and then sent to an Nvidia Embedded PC via a serial interface [11].

A photoplethysmography (PPG) system to determine whether the user is drowsy or not. The system detects the pulse rate through the skin contact of the user's finger on the system sensor [14].

This paper aims to detect the state of microsleeep when driving in a vehicle that takes a long time using the heart rate sensor as an indicator of the driver's condition in a normal, drowsy or microsleeep state and has an alarm feature that can alert drivers who may be microsleeeping by using photoplethysmography (PPG).

2. Methodology

2.1 Participants

25 participants (mean age of 23 years, male) were assigned from the population of students at Universiti Kebangsaan Malaysia (UKM) to take part in this study. Each participant was required to attend one session for data analysis and data storing.

All participants were needed to do daily work as individuals and return to their own college to rest at night. A microsleeep detection system will be placed during this time where the participants were required to place their finger on the PPG sensor during normal, drowsy and sleep condition after informing the time for each condition. Data receiving and recording can be done by remote through an Android smartphone application created to receive real time heart rate data with timestamp. Each participants will give input for only one day or night only.

2.2 Experiment Design and Procedure

The participant should attach the microsleeep detection system before going to bed or sleep. The attached device will receive and collect heart rate data from MAX30102 sensor. IoT features from ESP8266 Wifi module which creates connection between Android smartphone application with Arduino Nano via IoT website which stores data from sensor. Fig. 1 illustrates how MAX30102 sensor data is collected through participant's finger.



Fig. 1. Participant's finger on MAX30102 sensor

2.2 Experiment Equipment

MAX30102 module measurement was used in this study to collect the heart rate data of the driver while driving on the road. The heart rate for each condition of driver is different. Thus, PPG module or MAX30102 sensor module was used as heart rate monitoring to detect microsleeep condition on drivers. Fig. 2 shows the full details of MAX30102 module used for the system.

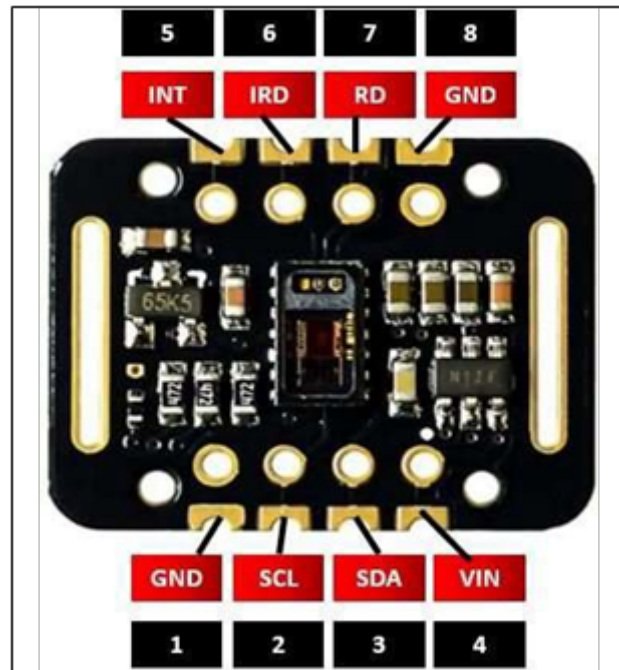

Fig. 2. MAX30102 module sensor

MAX30102 is an IC integrated pulse oximeter and heart rate sensor, from Analog Devices. It combines two LEDs, a photodetector, optimized optics, and low-noise analog signal processing to detect pulse oximetry (SpO₂) and heart rate (HR) signals. On the other side is a very sensitive photo detector. The idea is that you flash one LED at a time, track the amount of light that shines back on the detector, and based on the signature, it can measure blood oxygen levels and heart rate.

2.4 PPG Data Collection Preparation

Fig. 3 shows the full implementation of microsleep detection system.

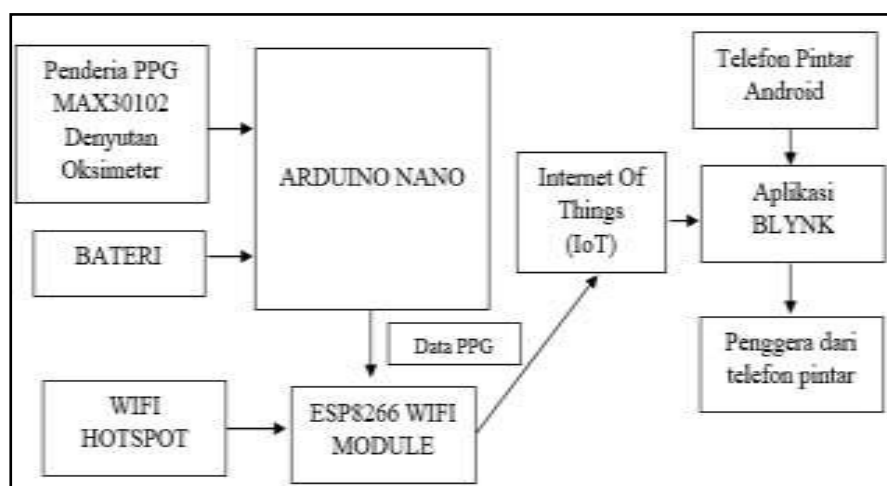

Fig. 3. Block diagram of the full system

The system starts with the continuous collection of raw data from the MAX30102 Pulse Oximeter sensor which is then processed to obtain the heart rate through Arduino IDE programming. The battery is used to power the input on the Arduino Nano and is connected to the ESP8266 WIFI Module. Wifi Hotspot is required to provide internet connection to ESP8266 and connect to Arduino

Nano. The processed heart rate data on the Arduino Nano will be transferred to the Internet of Things (IoT) website. After that, the BLYNK Application on the Android smartphone takes the data on the website to display the heart rate directly on the smartphone screen and can classify the driver's condition as either normal, sleepy or microsleep. If the state of microsleep is detected, the alarm system on the smartphone will work to surprise and warn the detection of microsleep.

Fig. 4 shows the flow of the full system in operating order. PPG sensor is used to get the heart rate, Arduino Nano with Arduino IDE as system software, ESP8266 Wi-Fi Module as IoT connection internet and Android application and Android smartphone alarm system is the proposed system and can detect driver's microsleep condition in the vehicle directly and precisely to avoid accidents on the road related to microsleep.

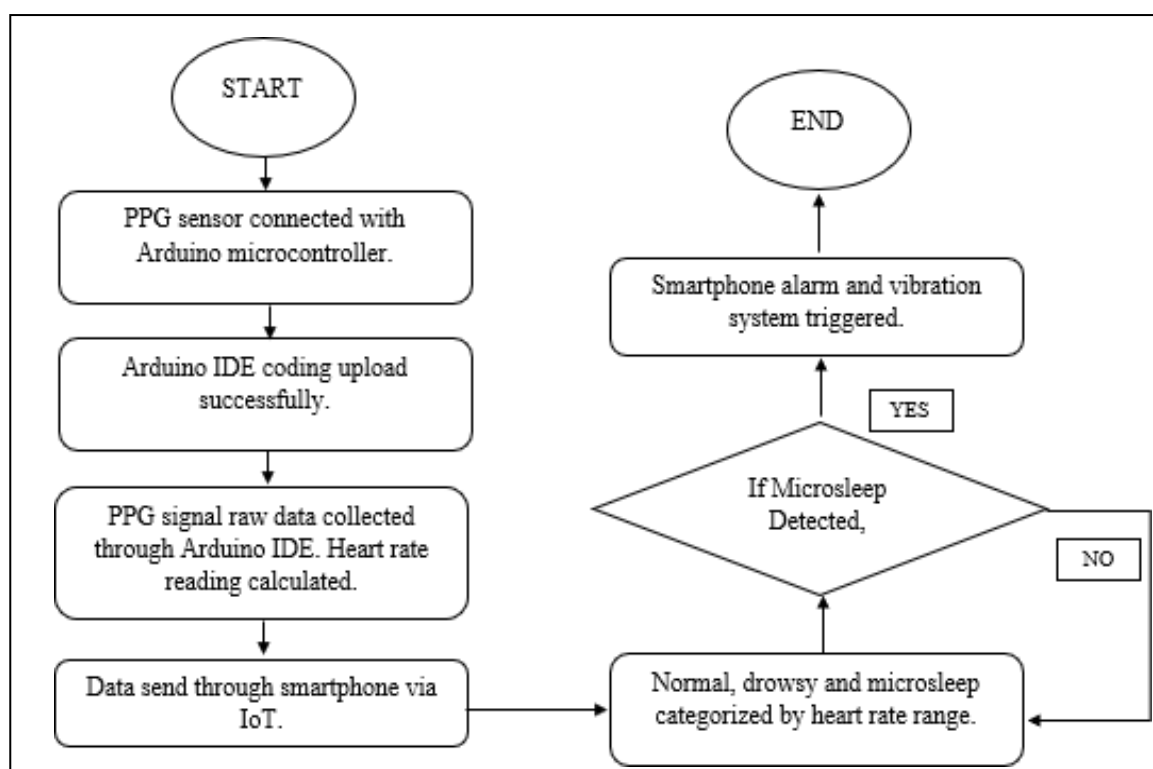

Fig. 4. Flowchart of the full system

2.4 SEMG Data Analysis

For the collection of analytical data, a total of 25 individuals participated in collecting samples. Each individual needs to be awake, drowsy, and asleep when taking heart rate readings to produce 3 different categories according to heart rate. This data collection is done at the student's residential college and not while driving for safety purposes. When an individual is awake, drowsy, or asleep, the microsleep detection system will be placed on the individual's finger and the data obtained will be recorded. A total of 25 samples for each category will be used to obtain a different heart rate range (BPM) and be used as a reference in Arduino programming. After that, the same 25 individuals will use a commercial sensor, a smartwatch and a pulse oximeter worn simultaneously by placing a finger on the PPG sensor for the purpose of comparison between the two sensors. The result of heart rate comparison data will be used as a reference and input to produce a correlation coefficient that shows the linearity between readings on PPG and commonly used commercial sensors. Fig. 5 shows an overview of the data collection carried out in residential colleges for determining the range of heart rate.



Fig. 5. Data collection on subject

To calculate the heart rate, we need at least 2 peaks as references. The parameters involved are the time for the 2 peaks to occur, the time between the two peaks (Time Interval) and the sampling rate (S.R), which is the time taken to obtain one sample. The heart rate (H.R) calculation based on peak detection follows Eq. (1).

$$H.R = 60 \times \frac{S.R}{Time\ interval} \quad (1)$$

Then, correlation coefficient will be calculated to determine the effectiveness of PPG sensor reading on heart rate. Pearson correlation coefficient (r) formula Eq. (2) will be used in data analysis where x_i is the total data set value of PPG samples, y_i is the total total data set value of commercial sensor samples, \bar{x} is mean of x_i and \bar{y} is mean of y_i with total of 25 samples taken.

$$r = \frac{\sum(x_i - \bar{x})(y_i - \bar{y})}{\sqrt{\sum(x_i - \bar{x})^2 \sum(y_i - \bar{y})^2}} \quad (2)$$

3. Results and Discussion

3.1 Arduino IDE Output

Fig. 6 shows the data output from serial plotter of Arduino IDE based on raw signal data obtained from MAX30102 pulse oximeter sensor. This set of data will be transferred to Microsoft Excel Data Streamer which will produce a more accurate output of sensor reading and clearer data analysis.

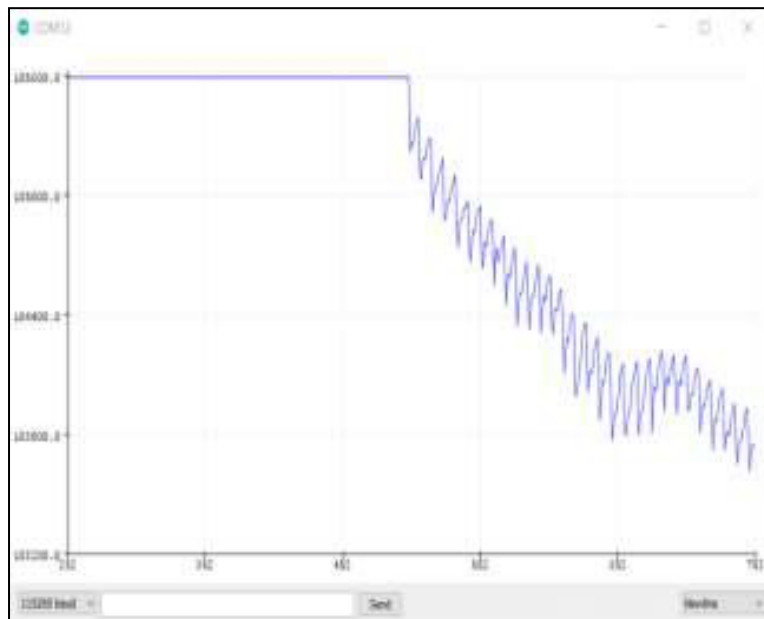

Fig. 6. Arduino IDE serial plotter output waveform

3.2 Android Application

For the heart rate display on the Android smartphone application, Fig. 7 shows the output results according to certain categories. Each category has a different display showing the current state of the driver at that time. This display can be accessed by the driver for monitoring. Notification system will pop up on Android system when certain threshold of heart rate detected where microsleep occurs. Data receiving and transferring uses IoT as a medium for communication. Fig. 8 shows BLYNK IoT website which stores and transfer heart rate data from PPG sensor to Android smartphone. This website also displays real time heart rate data with specific time stamps.



Fig. 7. Display on Android application

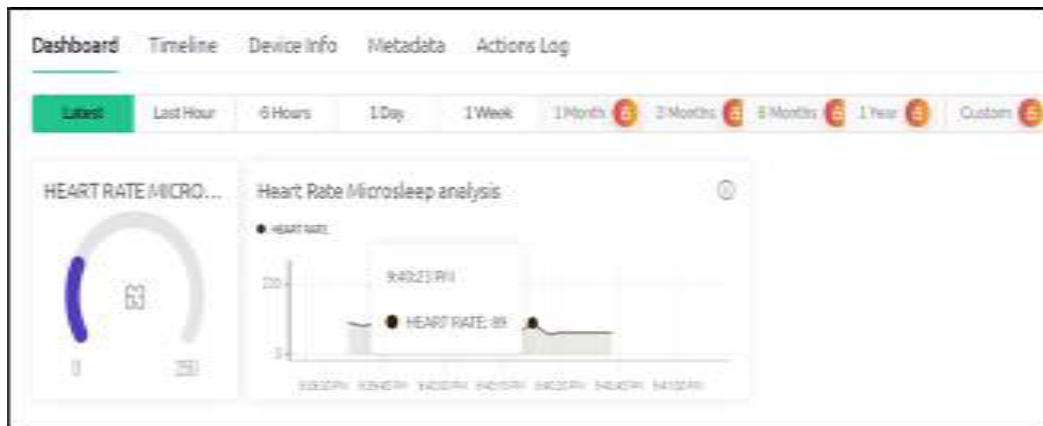

Fig. 8. BLYNK IoT website display

3.3 Data Analysis on PPG Sensor

Based on 25 samples obtained for each state of the subject, the heart rate range (BPM) of normal condition is ($79 \geq x > 62$), drowsy range at ($62 \geq x > 49$) and microsleep range at ($x \leq 49$). The heart rate range obtained is relevant because the normal or resting heart rate range for an adult individual is between 60 to 100 BPM and the sleeping heart rate range is between 40 to 50 BPM [15-17].

In this study, correlation coefficient is intended to evaluate the strength and direction of the linear relationship between pairs of variables. The correlation coefficient is a statistical measure of how linearly related two variables are. The correlation coefficient is a common tool for describing simple relationships without making statements about cause and effect. The Pearson correlation coefficient formula (2) was used for the calculation with 25 samples taken. Fig. 9 shows the correlation plot between PPG sensor and smartwatch sensor. Unavoidable

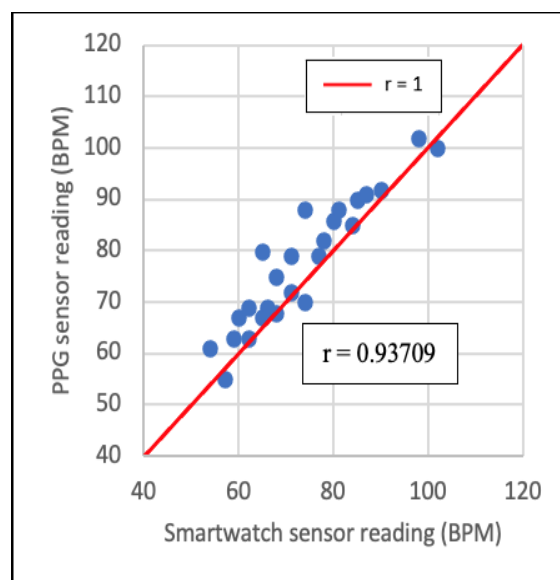

Fig. 9. Correlation graph plot between PPG and smartwatch sensor

Based on Fig. 10, the correlation coefficient for the relationship between heart rate readings on PPG and pulse oximeter ($r = 0.98734$) is more linear than smartwatch ($r = 0.93709$). This is because the pulse oximeter sensor is the same as the PPG system which uses pulses on the finger to obtain heart rate data.

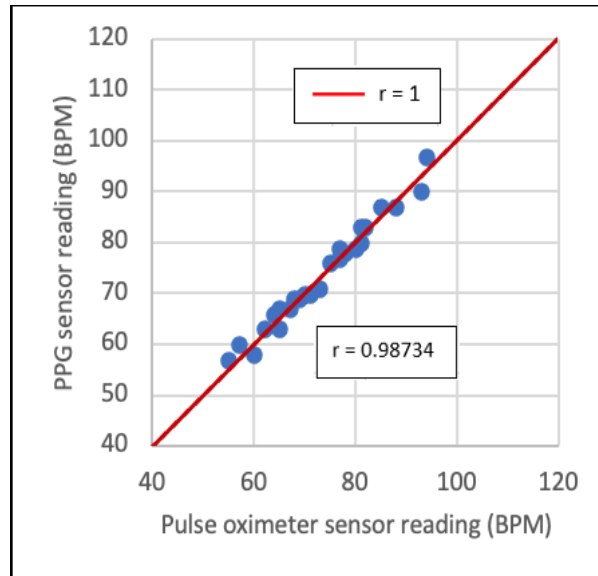

Fig. 10. Correlation graph plot between PPG and pulse oximeter sensor

4. Conclusions

Based on this research, it can be concluded that the design of a microsleep monitoring system using the PPG system has been successfully developed. The monitoring system with the method of calculating the driver's heart rate while driving was successfully used as an indicator to detect the state of microsleep by connecting the PPG system to the car's steering system without using it on the driver's body. The PPG sensor can give accurate readings to classify the driver's state of being awake, dozing or microsleep through the heart rate range found.

With IoT and Android applications, this research system successfully produced an alarm system for microsleep detection while driving. The ESP8266 can connect the Arduino with the BLYNK Android app to receive current heart rate data and display the latest driver status. The display on the BLYNK application successfully shows the driver's current state of normal, drowsy and microsleep. Existing notification and alarm systems on Android smartphones can generate sounds and vibrations to alert the driver when microsleep is detected through a certain heart rate range.

For more effective microsleep monitoring and alarm, more sensors such as image or video sensor can detect the face expression of the driver and more effective alarm system such as car horn system can make the drowsy or microsleep state of the driver to wake up from sleep.

Acknowledgement

Highly appreciation to the research team members from Universiti Kebangsaan Malaysia and Universiti Teknologi MARA, Cawangan Selangor, Kampus Dengkil for their dedication and contribution throughout this paper. This research was funded by the Ministry of Higher Education Malaysia and Universiti Kebangsaan Malaysia through FRGS research grants (Vote no: FRGS/1/2022/TK02/UKM/02/2 and a university research grant (Vote no. GGPM-2017-087), respectively.

References

- [1] Jabbar, R., M. Shinoy, M. Kharbeche, K. Al-Khalifa, M. Krichen, and K. Barkaoui. "Driver Drowsiness Detection Model Using Convolutional Neural Networks Techniques for Android Application." In *2020 IEEE International Conference on Informatics, IoT, and Enabling Technologies (IC IoT 2020)*, 237-242. 2020. <https://doi.org/10.1109/ICIoT48696.2020.9089484>
- [2] The Royal Society for the Prevention of Accidents. "Driver Fatigue and Road Accidents." February 2001.
- [3] Havârneanu, C. E., C. Măirean, and S. A. Popusoi. "Workplace Stress as Predictor of Risky Driving Behavior among Taxi Drivers. The Role of Job-Related Affective State and Taxi Driving Experience." *Safety Science* 111 (2019): 264–270. <https://doi.org/10.1016/j.ssci.2018.07.020>
- [4] Subha, R., J. Aravind, V. Santhalingam, and J. D. Sweetlin. "Drowsy Driving Detection System by Analyzing and Classifying Brain Waves." In *Proceedings of the 2nd International Conference on Electronics, Communication and Aerospace Technology (ICECA 2018)*, 667–672. 2018. <https://doi.org/10.1109/ICECA.2018.8474915>
- [5] Rohit, F., V. Kulathumani, R. Kavi, I. Elwarfalli, V. Kecojevic, and A. Nimbarte. "Real-time Drowsiness Detection Using Wearable, Lightweight Brain Sensing Headbands." *IET Intelligent Transport Systems* 11, no. 5 (2017): 255–263. <https://doi.org/10.1049/iet-its.2016.0183>
- [6] Vadlamudi, S., and A. Ahmadinia. "An Embedded Intelligence Engine for Driver Drowsiness Detection." *IET Computers and Digital Techniques* 16, no.1 (2022): 10–18. <https://doi.org/10.1049/cdt2.12036>
- [7] Gupta, S., P. Jain, and E. Rufus. "Drowsy Driver Alerting System." In *Proceedings of the 2nd International Conference on Electronics, Communication and Aerospace Technology (ICECA 2018)*, 1665–1670. 2018. <https://doi.org/10.1109/ICECA.2018.8474931>
- [8] IEEE Staff. *2019 2nd International Conference on Intelligent Computing, Instrumentation and Control Technologies (ICICT)*. IEEE, 2019a.
- [9] Daud, M. A., Faidhi, A. P. Ismail, N. M. Tahir, K. Daud, N. M. Kasim, and F. A. Mohamad. "Real Time Drowsy Driver Detection Using Image Processing on Python." In *2022 IEEE 12th International Conference on Control System, Computing and Engineering (ICCSCE)*, 131–136. Penang, Malaysia, 2022. <https://doi.org/10.1109/ICCSCE54767.2022.9935627>
- [10] Pham, N., T. Dinh, T. Kim, Z. Raghebi, N. Bui, H. Truong, T. Nguyen, F. Banaei-Kashani, A. Halbower, T. N. Dinh, V. Nguyen, and T. Vu. "Detection of Microsleep Events with a Behind-the-ear Wearable System." *IEEE Transactions on Mobile Computing*, 2021. <https://doi.org/10.1109/TMC.2021.3090829>
- [11] Gromer, M., D. Salb, T. Walzer, N. M. Madrid, and R. Seepold. "ECG Penderia for Detection of Driver's Drowsiness." *Procedia Computer Science* 159 (2019): 1938–1946. <https://doi.org/10.1016/j.procs.2019.09.366>
- [12] Anilkumar, C. V., A. Mansoor, R. Sahana, R. Thejashwini, and P. S. Anisha. "Design of Drowsiness, Heartbeat Detection System and Alertness Indicator for Driver Safety." In *2016 IEEE International Conference on Recent Trends in Electronics, Information and Communication Technology (RTEICT 2016 - Proceedings)*, 937–941. 2017. <https://doi.org/10.1109/RTEICT.2016.7807966>
- [13] Arunasalam, M., N. Yaakob, A. Amir, M. Elshaikh, and N. F. Azahar. "Real-Time Drowsiness Detection System for Driver Monitoring." In *IOP Conference Series: Materials Science and Engineering*, vol. 767, no.1. 2020. <https://doi.org/10.1088/1757-899X/767/1/012066>
- [14] Kurian, D., P. L. Johnson Joseph, K. Radhakrishnan, and A. A. Balakrishnan. "Drowsiness Detection Using Photoplethysmography Signal." In *Proceedings - 2014 4th International Conference on Advances in Computing and Communications (ICACC 2014)*, 73–76. 2014. <https://doi.org/10.1109/ICACC.2014.23>
- [15] Sleep Foundation. "What Is a Normal Sleeping Heart Rate?" Accessed January 22, 2023. <https://www.sleepfoundation.org/physical-health/sleeping-heart-rate>.
- [16] Mahmood, N. H., N. Uyop, N. Zulkarnain, F. C. Harun, M. F. Kamarudin, and A. Linoby. "LED Indicator for Heart Rate Monitoring System in Sport Application." In *2011 IEEE 7th International Colloquium on Signal Processing and its Applications*, 64-66. IEEE, March 2011. <https://doi.org/10.1109/CSPA.2011.5759843>
- [17] Harun, F. C., N. Zulkarnain, M. A. Aziz, N. H. Mahmood, M. F. Kamarudin, and A. Linoby. "Pulse Oximetry Color Coded Heart Rate Monitoring System Using Zigbee." In *5th Kuala Lumpur International Conference on Biomedical Engineering 2011: (BIOMED 2011) 20-23 June 2011, Kuala Lumpur, Malaysia*, 348-351. Springer Berlin Heidelberg, 2011. https://doi.org/10.1007/978-3-642-21729-6_90